

HX-P1010 SERIES

±10 VDC OUTPUT (Adjustable to ±5 VDC)



The UniMeasure HX-P1010 series position transducer provides an output voltage from -10 VDC to +10 VDC with adjustability to -5 VDC to +5 VDC. The zero position may be set within 10% to 90% of the total range of the transducer. The output voltage will be positive when the cable is extending from the zero position and negative when retracting from the zero position. The span may be adjusted to the maximum output voltage within 50% to 100% of the longest possible travel from the zero position, whether positive or negative.

A dual voltage input (+15 VDC, -15 VDC and COMMON) is required but a single excitation voltage option is available to accommodate input voltages in the range of 4.9 to 30 VDC.

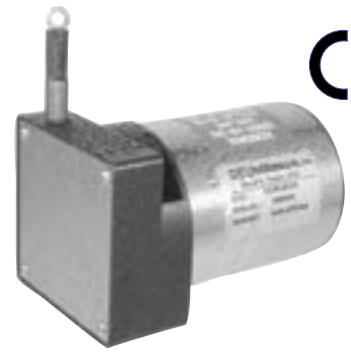

SPECIFICATIONS

General

Available Measurement Ranges..... See Supplemental Data¹, Table 12
 Connector..... MS3102E-14S-6P
 Mating Connector (included)..... MS3106E-14S-6S

Performance

Linearity
 2", 3", 4", 5" & 6" Ranges ±0.30% Full Scale
 10", 15", 20" & 25" Ranges..... ±0.20% Full Scale
 All other ranges ±0.15% Full Scale
 Repeatability..... ±0.015% Full Scale
 Resolution Essentially Infinite

Electrical

Output..... -10 VDC to +10 VDC
 Excitation Voltage +15 VDC ±10%, -15 VDC ±10%
 Input Current 25 mA max.
 Output Impedance..... 1.0Ω max.
 Output Load..... 5KΩ min.
 Capacitive Load..... 1000 pF
 Zero Adjustment Range 10% to 90% of Range
 Span Adjustment Range 50% to 100% of Longest Possible Travel from Zero Position
 Protection Reversed Polarity
 Temperature Stability..... 0.02%/°C of Span

Environmental

Operating temperature -40°C to +85°C
 Storage Temperature -55°C to +100°C
 Operating humidity 100%
 Vibration 15 G's 0.1 ms max.
 Shock..... 50 G's 0.1 ms max.
 Ingress Protection
 Exclusive of Wire Rope Area..... NEMA 4 (IP-65)
 Optional Ingress Protection NEMA 6 (IP-68)

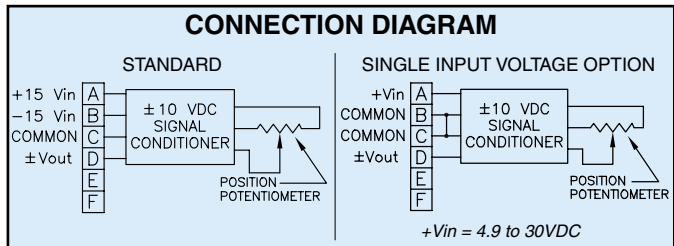

FOOTNOTES TO SPECIFICATIONS

1. Supplemental Data section located at end of HX Series pages.

Model Number Configuration

Range

Select measurement range from Supplemental Data, Table 12, Insert corresponding Measurement Range Designator

HX-P1010-

Wire Rope

*.....Stainless Steel (See Supplemental Data, Table 12)
NJC.....Ø.018 (0,45 mm) Nylon Jacketed Stainless Steel Ranges to 80" (2m) only.
NJC037.....Ø.037 (0,94 mm) Nylon Jacketed Stainless Steel Ranges 100" (2.5m) to 500" (12.7m) only.

Wire Rope Tension

*..... Standard
004..... Reduced (Ranges to 80" only)

Wire Rope Exit Direction

*..... Top Exit
E1..... Side Exit (Left)
E2..... Side Exit (Right)
E3..... Bottom Exit

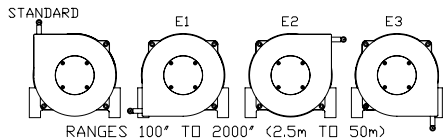
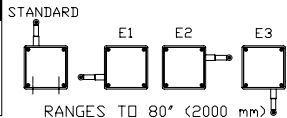

Housing

*..... NEMA 4 (IP-65) Aluminum
N6..... NEMA 6 (IP-68) Aluminum
SS..... NEMA 6 (IP-68) Corrosion Resistant Stainless Steel and Non-Metallic Construction

Electrical Interface

*.....Mating Connector Included (See note 1 below)
L3M.....3 m (10') electrical cable (See note 2 below)
L4M.....4 m (13.5') electrical cable (See note 2 below)
L5M.....5 m (16.5') electrical cable (See note 2 below)
L6M.....6 m (20') electrical cable (See note 2 below)
L7M.....7 m (23') electrical cable (See note 2 below)
 1. Applies to NEMA 4 Housing option only. Does not apply to N6 or SS Housing options.
 2. Select one of options L3M through L7M when electrical cable is required with mating connector when Housing option NEMA 4 is also selected. Select one of options L3M through L7M when Housing option N6 or SS is selected. Connector is **not** available with Housing option N6 or SS.

Electrical Output Polarity

*..... Standard (increasing output as wire rope is extended)
R..... Reversed (decreasing output as wire rope is extended)

Electrical Input Voltage

*..... Standard ±15 VDC Input
SI..... 4.9 to 30 VDC Single input



NOTE

- *—Asterisk items are standard configuration. No option designator is required.
- Shaded options available at additional cost.
- See Supplemental Data for options.

Example

HX-P1010-50-NJC-SI24

ADDITIONAL OPTIONS

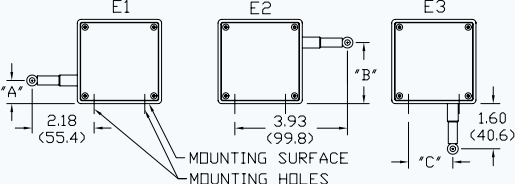
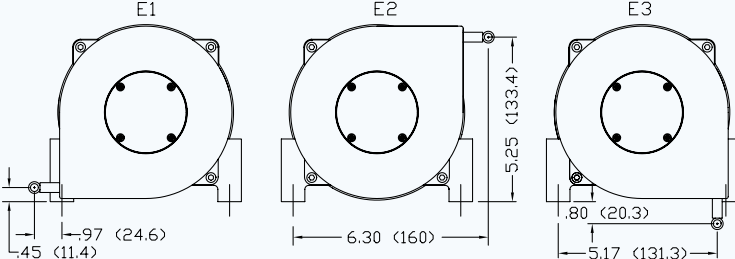
OPTION	OPTION DESIGNATOR	DESCRIPTION																												
Nylon jacketed wire rope (Ranges to 80" only)	NJC	Replaces standard stainless steel wire rope with Ø.018 nylon jacketed wire rope. This option increases wire rope life dramatically but may increase non-linearity by as much as ±.05% of full scale.																												
Nylon jacketed wire rope (Ranges 100" to 500" only)	NJC037	Replaces standard stainless steel wire rope with Ø.037 nylon jacketed wire rope.																												
Reversed output	R	Output is at a maximum when wire rope is fully retracted. Output decreases as wire rope is extended. Does not apply to velocity signal.																												
NEMA 6, IP-68 capability	N6	 <p>Connector is replaced with a bulkhead fitting and a designated length of urethane jacketed, shielded, twisted pair cable. Retraction mechanism and electrical components are sealed to NEMA 6, IP-68 capability. No connector.</p>																												
Corrosion Resistant Construction	SS	<p>All external anodized aluminum parts of transducer are replaced with stainless steel and corrosion resistant plastic. Transducer is sealed to NEMA 6, IP-68 capability. Urethane jacketed, shielded, twisted pair cable exits unit. No connector.</p> 																												
Non-standard potentiometer (Applies to HX-PA only)	PXK	<p>Replace "X" in option designator with required potentiometer value in K ohms. Non-standard potentiometer linearity is as follows:</p> <p>Ranges 0 to 2" to 0 to 5" ±1.00% of full scale Ranges 0 to 10" to 0 to 25" ±0.50% of full scale Ranges 30" and above ±0.25% of full scale Note: This option is subject to potentiometer availability.</p>																												
Alternate wire rope exit Measurement ranges to 80" (2.0 m)	E1, E2, E3	 <table border="1"> <thead> <tr> <th>RANGE</th> <th>"A"</th> <th>"B"</th> <th>"C"</th> </tr> </thead> <tbody> <tr> <td>2", 10"</td> <td>1.12 (28.4)</td> <td>1.79 (45.5)</td> <td>1.21 (30.7)</td> </tr> <tr> <td>3", 15", 30"</td> <td>.96(24.4)</td> <td>1.95 (49.5)</td> <td>1.37 (34.8)</td> </tr> <tr> <td>4", 20", 40"</td> <td>.80 (20.3)</td> <td>2.11 (53.6)</td> <td>1.53 (38.9)</td> </tr> <tr> <td>5", 25", 50"</td> <td>.64 (16.3)</td> <td>2.27 (57.7)</td> <td>1.69 (42.9)</td> </tr> <tr> <td>6", 60"</td> <td>.49 (12.4)</td> <td>2.42 (61.5)</td> <td>1.84 (46.7)</td> </tr> <tr> <td>80"</td> <td>.25 (6.4)</td> <td>2.66 (67.6)</td> <td>2.08 (52.8)</td> </tr> </tbody> </table> <p>Dimensions in brackets are millimeters.</p>	RANGE	"A"	"B"	"C"	2", 10"	1.12 (28.4)	1.79 (45.5)	1.21 (30.7)	3", 15", 30"	.96(24.4)	1.95 (49.5)	1.37 (34.8)	4", 20", 40"	.80 (20.3)	2.11 (53.6)	1.53 (38.9)	5", 25", 50"	.64 (16.3)	2.27 (57.7)	1.69 (42.9)	6", 60"	.49 (12.4)	2.42 (61.5)	1.84 (46.7)	80"	.25 (6.4)	2.66 (67.6)	2.08 (52.8)
RANGE	"A"	"B"	"C"																											
2", 10"	1.12 (28.4)	1.79 (45.5)	1.21 (30.7)																											
3", 15", 30"	.96(24.4)	1.95 (49.5)	1.37 (34.8)																											
4", 20", 40"	.80 (20.3)	2.11 (53.6)	1.53 (38.9)																											
5", 25", 50"	.64 (16.3)	2.27 (57.7)	1.69 (42.9)																											
6", 60"	.49 (12.4)	2.42 (61.5)	1.84 (46.7)																											
80"	.25 (6.4)	2.66 (67.6)	2.08 (52.8)																											
Alternate wire rope exit Measurement ranges 100" (2.5 m) and greater.	E1, E2, E3	 <p>Dimensions in brackets are millimeters.</p>																												

Specifications subject to change without notice.

HX SERIES

SUPPLEMENTAL DATA



Typical HX mounting bolts.

MECHANICAL SPECIFICATIONS

Mechanical Specifications

- Available Measurement Ranges.....See Table 12
- Construction
 - Ranges 80" (2 m) and under.....Anodized Aluminum Mounting Base, Stainless Steel & Anodized Aluminum Housing
 - Ranges 100" (2.5 m) and greaterStainless Steel Mounting Base High Impact, Corrosion Resistant Thermoplastic Housings
- Wire Rope TensionSee Table 12
- Wire Rope Diameter.....See Table 12
- WeightSee Table 12
- Connector.....MS3102A-14S-6P
- Mating Connector (included).....MS3106E-14S-6S
- Optional NEMA 6 Capability.....Bulkhead fitting with shielded, twisted pair cable
- Life*
 - Ranges 2" to 6"5,000,000 full stroke cycles
 - Ranges 10" to 25"500,000 full stroke cycles
 - Ranges 30" to 400"250,000 full stroke cycles
 - Ranges 500" to 2000"200x10⁶ lineal inches

* with 1K ohm potentiometer, wire rope misalignment 2° maximum at full stroke, relatively dust free environment, nylon jacketed wire rope on units with ranges 80" and less.

Use value from this column to indicate overall measurement range

Check mark indicates available measurement range

TABLE 12

MEASUREMENT RANGE DESIGNATOR	STANDARD MEASUREMENT RANGES		APPLICABLE SERIES			WIRE ROPE TENSION (NOMINAL)		WIRE ROPE DIAMETER		TRANSDUCER WEIGHT		Product Photo	
	(in)	(mm)	HX-PA HX-PB HX-P420 HX-P510 HX-P1010	HX-EP	HX-V HX-VP	(oz)	(N)	(in)	(mm)	(lb)	(Kg)		
2	2	50	✓	-	✓	34	9.4	.016	0.4	2	0.9		
3	3	75	✓	-	✓	24	6.7	.016	0.4	2	0.9		
4	4	100	✓	-	✓	24	6.7	.016	0.4	2	0.9		
5	5	125	✓	-	✓	19	5.3	.016	0.4	2	0.9		
6	6	150	✓	-	✓	24	6.7	.016	0.4	2	0.9		
10	10	250	✓	✓	✓	34	9.4	.016	0.4	2	0.9		
15	15	390	✓	-	✓	24	6.7	.016	0.4	2	0.9		
20	20	500	✓	-	✓	24	6.7	.016	0.4	2	0.9		
25	25	640	✓	✓	✓	19	5.3	.016	0.4	2	0.9		
30	30	750	✓	-	✓	24	6.7	.016	0.4	2	0.9		
40	40	1000	✓	-	✓	24	6.7	.016	0.4	2	0.9		
50	50	1250	✓	✓	✓	19	5.3	.016	0.4	2	0.9		
60	60	1500	✓	✓	✓	24	6.7	.016	0.4	2	0.9		
80	80	2.0m	✓	✓	✓	21	5.8	.016	0.4	2	0.9		
100	100	2.5m	✓	✓	✓	36	10.0	.024	0.6	6.8	3.1		
120	120	3.0m	✓	✓	✓	36	10.0	.024	0.6	6.8	3.1		
150	150	3.8m	✓	✓	✓	36	10.0	.024	0.6	6.8	3.1		
200	200	5.0m	✓	✓	✓	36	10.0	.024	0.6	6.8	3.1		
250	250	6.3m	✓	✓	✓	36	10.0	.024	0.6	6.8	3.1		
300	300	7.5m	✓	✓	✓	36	10.0	.024	0.6	6.8	3.1		
350	350	8.8m	✓	✓	✓	36	10.0	.024	0.6	6.8	3.1		
400	400	10.0m	✓	✓	✓	36	10.0	.024	0.6	6.8	3.1		
500	500	12.5m	✓	✓	✓	36	10.0	.024	0.6	8.6	3.9		
600	600	15.2m	✓	✓	✓	36	10.0	.024	0.6	8.6	3.9		
800	800	20.3m	✓	✓	✓	36	10.0	.024	0.6	8.6	3.9		
1000	1000	25.4m	✓	✓	-	36	10.0	.024	0.6	12.0	5.4		
1200	1200	30.4m	✓	✓	-	36	10.0	.024	0.6	12.3	5.6		
1600	1600	40.6m	✓	✓	-	36	10.0	.024	0.6	14.1	6.4		
1800	1800	45.7m	✓	✓	-	36	10.0	.021	0.6	15.9	7.2		
2000	2000	50.8m	✓	✓	-	36	10.0	.021	0.5	16.3	7.4		

Specifications subject to change without notice.

DIMENSIONAL INFORMATION

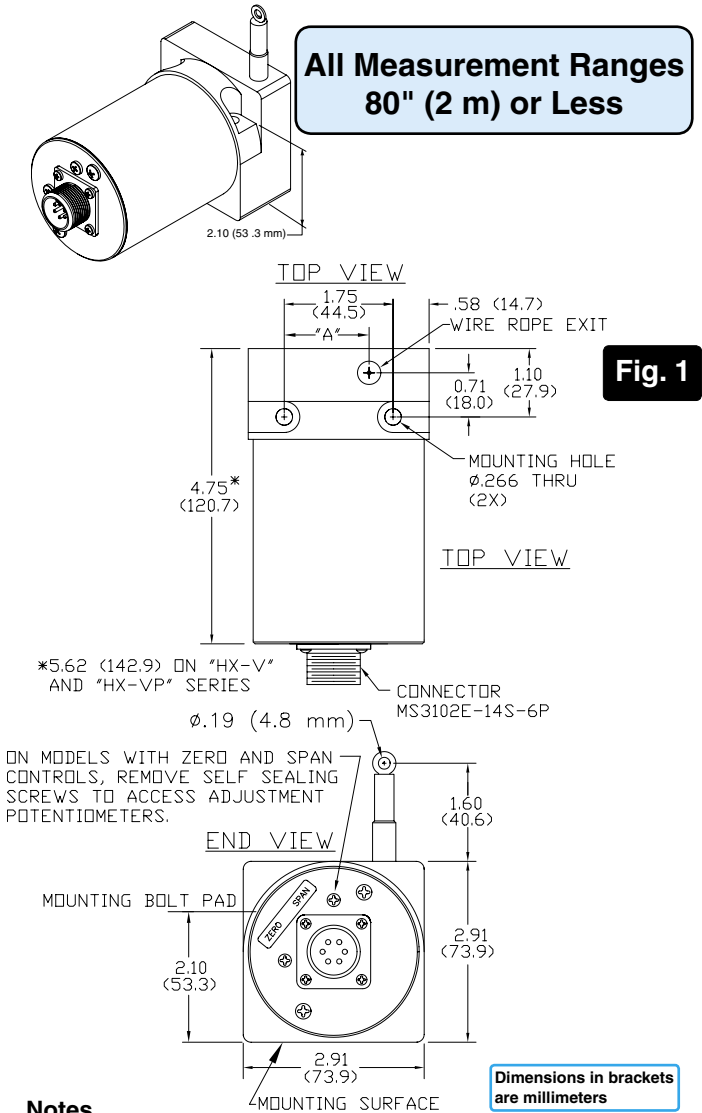

Notes

1. Transducer mounts with ϕ .25 or M6 socket head cap bolts.

Table 13

RANGE	"A"
2", 10"	1.21 (30.7)
3", 15", 30"	1.37 (34.8)
4", 20", 40"	1.53 (38.9)
5", 25", 50"	1.69 (42.9)
60"	1.84 (46.7)
80"	2.08 (52.8)

Table 14

RANGE	DIM "A"	DIM "B"
Ranges to 800"	7.70 (196)	3.80 (97)
1000" to 2000"	11.0 (280)	5.60 (142)

Notes

1. Transducer mounts with ϕ .50 or M12 socket head cap bolts.
2. Dimension "C" is the cable offset that occurs as the cable is extended from the transducer.

For "C" in inches, $C = .0016 \times E$ where E = extension in inches.

For "C" in millimeters, $C = .0016 \times E$ where E = extension in mm.

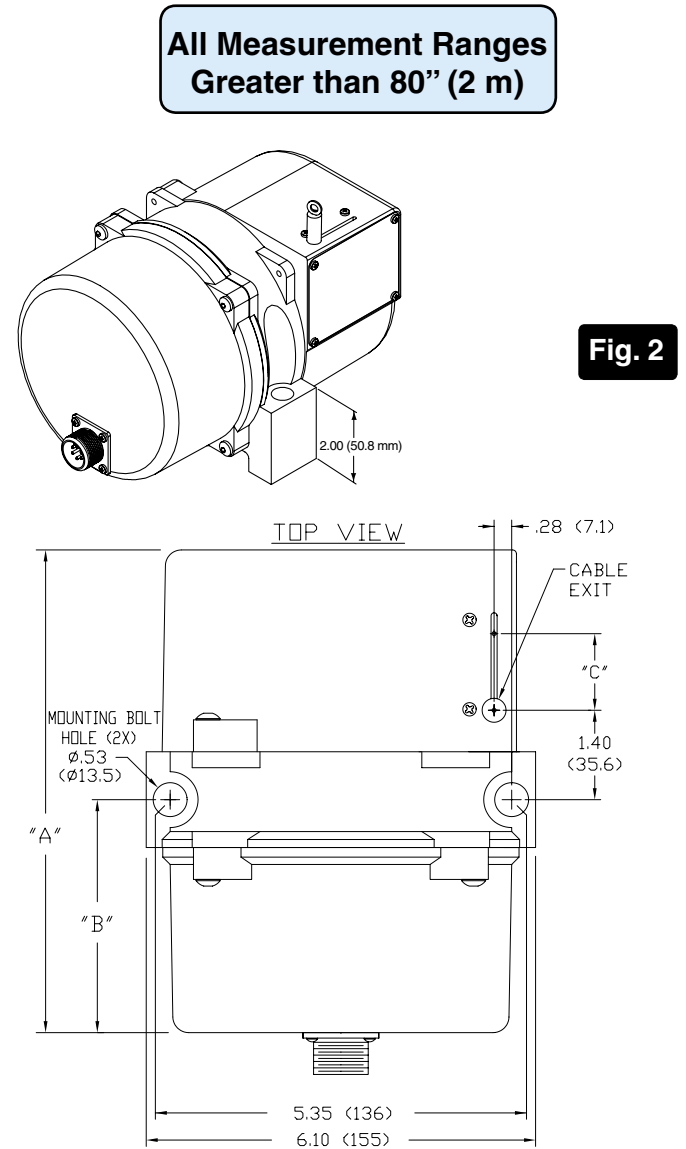

Dimensions in brackets are millimeters

Specifications subject to change without notice.