

JX-EP Series Installation Guide

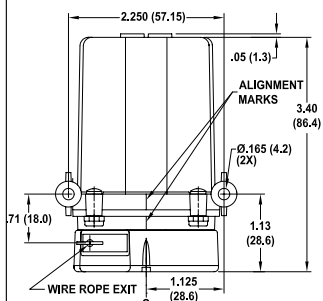

Range Designator	Dim A (in) (mm)	Nominal Cable Tension (oz) (N)
10	.36 9.1	16 4.4
15, 30	.50 12.7	14 3.9
20, 40	.66 16.7	11 3.1
25, 50	.82 20.8	8 2.2

Ranges to 50" (1250 mm)

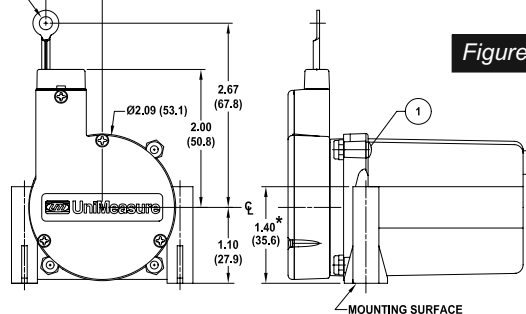
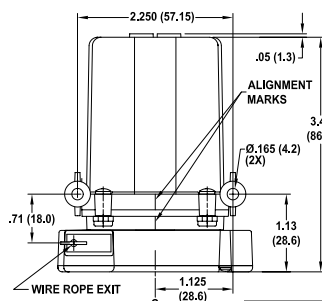

Figure 1

*Mounting screws must accommodate this distance.



Range Designator	Dim A (in) (mm)	Nominal Cable Tension (oz) (N)
60	.98 24.9	10 2.8
80	1.28 32.5	8.6 2.4

Ranges to 80" (2000 mm)

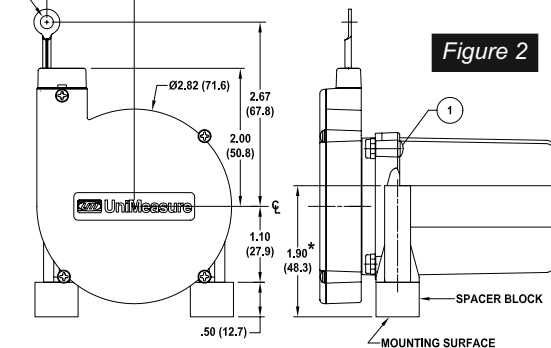

Figure 2

*Mounting screws must accommodate this distance.

Mounting

- To maximize wire rope life, align transducer with moving element so that wire rope exits parallel to axis of wire rope exit hole within 2° (see Figure 3).
- Use Table A or B to determine wire rope exit location relative to transducer mounting holes.
- Mount unit with two #8 or two M4 (or smaller) pan head machine screws. On units with ranges of 60" (1500 mm) or 80" (2000 mm), place spacer blocks under mounting pods as shown in Figure 2. Torque 8-32 screws to **8 lb-in** maximum. Torque M4 screws to **0.80 N-m** maximum.

Rotation of Wire Rope Exit

To rotate wire rope exit location, loosen four screws (item 1, Figures 1 & 2) which retain mechanism to mounting housing. Note that alignment marks on mechanism occur at 90° intervals. Rotate housing to desired position and torque screws to **50 oz-in (0.35 N-m)** maximum.

Replacement Wire Rope Wipers

The JX transducer contains wire rope dust wipers which are located just beneath the wire rope exit location. Periodic replacement of the dust wipers may be necessary depending upon the amount of dust in the operating environment. To access the dust wipers, remove the Dust Wiper Cover by placing a small blade screw driver into the slot as shown in Figure 3 and pry upward while squeezing the ends of the cover. The wipers may be removed with tweezers and cleaned or replaced. The replacement wiper kit which contains six pair of prelubricated wipers is UniMeasure part number 10198. To install replacement wipers, place a wiper into wiper opening on both sides of the wire rope. Press Dust Wiper Cover into place until detented.

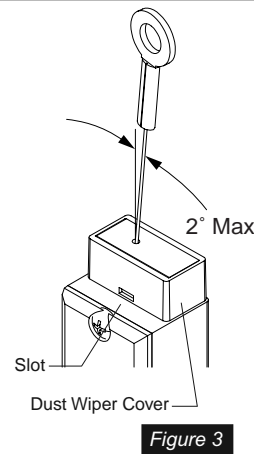

Figure 3

Electrical Output Option

Option	Output Type	Input Voltage	Output Stage	Waveform	Cable Wiring	Optional Connector
1	5 VDC TTL Two Channel Current Sinking	+5 VDC ±5%				<p>Viewed from solder side of mating connector</p> <p>Note: With output option 1 channels A0 and B0 are not connected.</p>
2	5 V TTL Current Sinking Differential Line Drive	+5 VDC ±5%				
3	5 VDC TTL Push Pull Differential Line Drive	+5 VDC ±5%				
4	8 to 28 V Current Sinking Differential Line Drive	+8 to 28 VDC				
5	8 to 28 V Push Pull Differential Line Drive	+8 to 28 VDC				