

HX-VP510 Series Installation Guide

Wiring and Circuit Diagram

Model HX-VP510

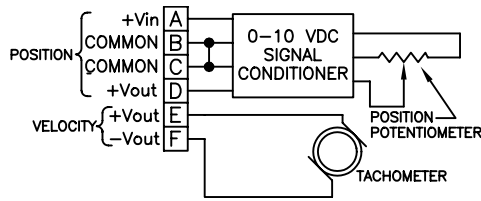

Velocity

The tachometer is self energizing and requires no input voltage.

Excitation Voltage 11 to 35 VDC

Excitation Current 40 mA max.

Output Impedance 10 Ω max.

Output Load 5KΩ min.

As shown in the diagram above, both commons on pins "B" and "C" are connected together internally at the transducer, so that either a 3-wire or 4-wire connection to the transducer may be made.

With small blade type screwdriver (.105" max. blade width X .023" max. blade thickness), adjust the *Zero* and *Span* controls on the transducer to set zero output voltage and maximum output voltage. **Note:** The *Zero* and *Span* controls are somewhat interactive and may require several iterations to obtain the desired zero and maximum settings.

Extend the cable (on angular position transducers, rotate shaft) of the transducer to the desired zero position (must be within 0% to 30% of range.) Adjust the *Zero* control so that the output voltage is zero. Then extend the cable (on angular position transducers, rotate shaft) to the desired maximum position (must be within 80% to 100% of range.) Adjust the *Span* control for maximum output voltage required (unit will adjust from 5 VDC to 10 VDC). Recheck the zero setting and adjust if necessary. Recheck the Span setting and readjust if necessary.

Dimensional Information

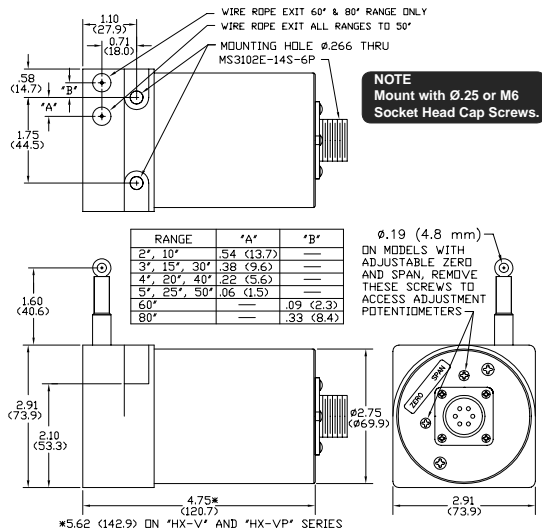

Alternate Wire Rope Exit

Note: Dimensions in brackets are millimeters.

RANGE	"A"	"B"	"C"
2", 10"	1.12 (28.4)	1.79 (45.5)	1.21 (30.7)
3", 15", 30"	.96(24.4)	1.95 (49.5)	1.37 (34.8)
4", 20", 40"	.80 (20.3)	2.11 (53.6)	1.53 (38.9)
5", 25", 50"	.64 (16.3)	2.27 (57.7)	1.69 (42.9)
60"	.49 (12.4)	2.42 (61.5)	1.84 (46.7)
80"	.25 (6.4)	2.66 (67.6)	2.08 (52.8)

Alternate Wire Rope Exit

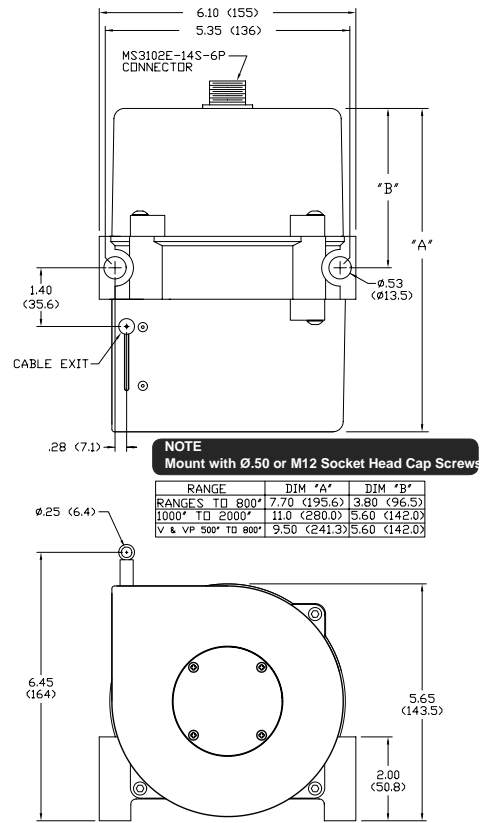
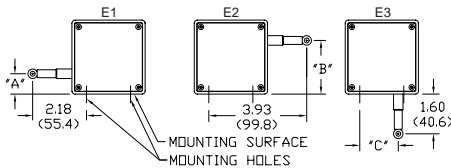

DIMENSIONS IN BRACKETS ARE MILLIMETERS

Alternate Wire Rope Exit

